



COMMERCIAL

HEAT PUMP WATER HEATERS

EMERGE™-i SMART COMMERCIAL LIGHT DUTY HEAT PUMP WATER HEATER WITH HOT WATER+ TECHNOLOGY

The EMERGE-i smart commercial light duty heat pump water heater with hot water+ technology from State can now deliver more hot water than other standard electric water heater thanks to the innovative smart valve technology. The heat pump technology is up to 4 times more efficient than standard electric water heaters saving you more every year.

HOW DO THEY WORK?

- Absorb ambient heat from the surrounding air to heat water using a compressor
- Self-contained heat pump unit is integrated into the top of the tank
- Backup electric elements can supplement the heat pump depending on operating mode, environmental conditions and hot water demand

EXCEPTIONAL ENERGY EFFICIENCY

- Improved efficiency up to 3.88 Uniform Energy Factor (UEF)
- Heat pump can work down to 37°F ambient for more days of high efficiency operation

MORE HOT WATER

- Choose from three Hot Water+ levels for up to 40% more hot water than a standard heat pump
- Guest Mode provides maximum hot water for up to seven days
- Innovative digital smart valve

ICOMM™ SMART CONNECTIVITY

- Monitor and control your water heater through the free State app
- Connect through a local Wi-Fi network or directly to the water heater through Bluetooth
- If applicable download the Time of Use schedule of your local electric utility to prioritize heating when the rates are most affordable
- Receive alerts and notifications

LEAK PROTECTION TECHNOLOGY

- Smart anode adapts to local water conditions to protect and extend the life of the water heater
- Controls regulate depletion of the anode to extend the life of the anode allowing superior tank protection far longer than standard anode rods
- User is notified when the anode is consumed and needs to be replaced
- Smart sensor leak detection and automatic water shutoff for added peace of mind and enhanced protection

WHISPER QUIET OPERATION AT 45 DBA

- No vibration isolation kit required

FLEXIBLE DESIGN

- Contractor preferred top water connections
- Zero clearance required on sides and back to fit in tighter spaces
- 450 ft³ space requirement is lower than other heat pump water heaters plus integrated ducting adapters for easy installation in smaller spaces
- Ideal for Gas Stations, Doctors Offices, and Retail



QUALIFIES FOR MANY STATE AND LOCAL UTILITY REBATES - CHECK STATEWATERHEATERS.COM



SOLID. STATE.

Model Number	Nominal Capacity	Rated Storage Volume	UEF	COP*	First Hour Rating (gallons)	Recovery in GPH 90°F Rise	Dimensions in Inches							Approx Shipping Weight (lbs)	Warranty Term
							A	B	C	D	E	F	G		
CSHP-40	40	36	3.60	4.16	55	28	64.75	20	41.5	3.75	8	43.5	46.5	191	3
CSHP-50	50	46	3.68	4.07	65	28	63	22	40.5	3.75	8	43.5	48	196	3
CSHP-66	66	68	3.84	4.10	83	28	61.5	26.5	38.25	4	8	41.25	46	284	3
CSHP-80	80	81	3.88	4.05	95	28	69	26.5	46.5	4	8	50.5	54.5	302	3

Top T&P option not available.

*COP tested in Heat Pump only mode at 240V, 67°F, and 50% Relative Humidity. 208V operation will result in derated outputs.

MULTIPLE OPERATING MODES

Choose from multiple modes to match water heating needs and environmental conditions. Use Hot Water+ in conjunction with other modes to customize the amount of hot water for daily operations

STANDARD MODES:

- Hot Water+ levels can be used to customize the amount of hot water for daily operations
- Hybrid (Default): Hot water delivery balanced with energy saving performance
- Heat Pump: Maximum energy efficiency

TEMPORARY MODES:

- Guest: Provides maximum hot water for up to seven days
- Electric: Uses only the electric heating elements
- Vacation: Reduce energy use while you are away

ADVANCED QUALIFICATIONS:

- ASSE 1082
- California Title 24 JA13 Qualified
- CTA-2045 (AC)
- ENERGY STAR®
- HUD Compliant
- NEEA Tier 4
- OpenADR 2.0b VEN
- Utility Demand Response Advanced Load-Up Capable

OTHER FEATURES:

- Easily accessible front mounted junction box
- R-134a Refrigerant
- Environmentally-friendly, non-CFC foam insulation
- Durable, enhanced-flow brass drain valve
- CSA certified and ASME rated temperature & pressure relief valve

OPERATING REQUIREMENTS:

- Requires provision for non-acidic condensate draining; if a suitable drain is not available a condensate pump is required
- 208/240 VAC 60Hz single phase 30 amp power supply

3-YEAR LIMITED WARRANTY

- For complete information, consult written warranty or go to statewaterheaters.com

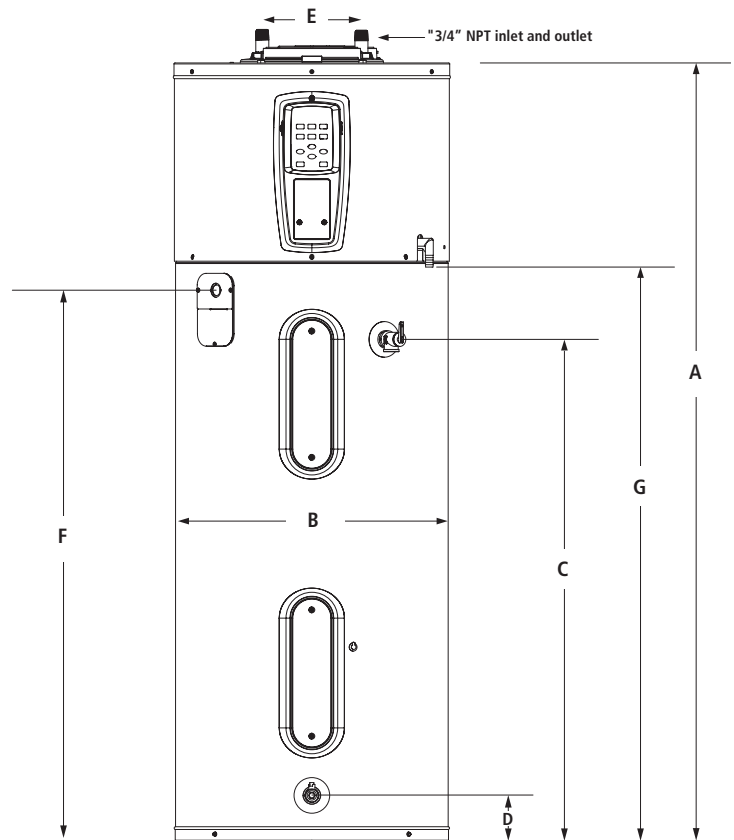

iCOMM™ SMART CONNECTIVITY

Download the free State app to get started.

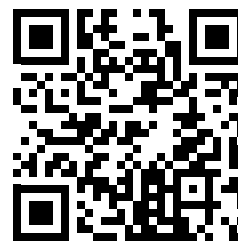

Apple logo and Apple App Store Logo are trademarks of Apple Inc. Google Play and the Google Play logo are trademarks of Google LLC.



COMMERCIAL HEAT PUMP WATER HEATERS

Technical Characteristics	
Model Type	Integrated Heat Pump Water Heater
Power Specification	208/240Vac ~ 60Hz 1Ph
HP - Rated Input Power	356 W @ 240Vac and 358 W @ 208Vac
HP Rated Heating Output Capacity	Up to 1.48 kW
Electrical Heating Capacity	4.5 kW @ 240Vac and 3.38 kW @ 208Vac
Maximum Operation Current	23.6 A @ 240Vac and 25.8 A @ 208Vac
Compressor Maximum Current	10 A @ 240Vac and 11.5 A @ 208Vac
Fan Maximum Current	0.5 A
Fan - Rated Input Power	20 W
Fan air flow	180 CFM
Unit Operation Noise	45 dB (A)
Cooling Capacity	~1.1 kW (3.75 kBTU/hr)
Operation Modes	Efficiency, Hybrid, Electric
Refrigerant	R134a
Refrigerant Charge Quantity	1.544 Lbs (700 g)
Operating Water Temperature	55 - 150°F (13 - 66°C)
Operating Ambient Temperature	36 - 124°F (2.2 - 51°C)

*COP tested in Heat Pump only mode at 240V, 67°F, and 50% Relative Humidity

SPECIFICATIONS

The heater(s) shall be Commercial Heat Pump Model _____ as manufactured by State Water Products Company or equivalent. Heater(s) shall be rated at a total system kW = 5.9kW (4.5 electrical elements and 1.4kW of heat pump) @ 240V or 4.88 kW @ 208V, single phase, 60 cycle AC as listed by Underwriters' Laboratories. Models must have a minimum UEF of 3.60 and meet National Sanitation Foundation NSF-5 requirements. Water heater shall have LCD display with built-in diagnostic and troubleshooting information. Tank(s) shall be 40/50/66/80 nominal gallon capacity with 150 psi working pressure and equipped with a smart anode that notifies user when anode is depleted. All internal surfaces of the heater(s) exposed to water shall be lined with Blue Diamond® glass lining and contain a DynaClean™ automatic sediment-cleaning system. The heat pump water heater(s) shall be capable of operating in Hybrid, Heat Pump, Guest, Electric, and Vacation modes and in temperatures ranging between 36°F - 124°F. The heat pump water heater(s) shall have a digital smart valve to automatically mix hot water to a desired setpoint. The heat pump water heater(s) shall contain a smart leak detection sensor and automatic water shut off valve for enhanced protection. The heat pump water heater(s) shall have 0" clearances on the back and sides as well as operate at no more than 45dBA. The control(s) shall have built-in WiFi to connect to State's free application, iCOMM, to monitor and control the water heater. The control(s) shall support demand response by having a built-in CTA-2045 port and by being California Title 24 compliant, JA-13 qualified. The water heater(s) shall contain environmentally friendly, non-CFC foam insulation, a durable, enhanced-flow brass drain valve, and a CSA certified and ASME rated temperature & pressure relief valve. 3/4" NPT inlet and outlet water connections shall be provided. The water heater tank(s) shall have a three year limited warranty; the compressor, refrigeration components and all other parts shall have a one year limited warranty. Fully illustrated instruction manual to be included.

FOR MORE INFORMATION ON CALL 1-800-365-0024. STATE WATER HEATERS RESERVES THE RIGHT TO MAKE PRODUCT CHANGES OR IMPROVEMENTS WITHOUT PRIOR NOTICE.